

8008256
FILTER / SILENCER

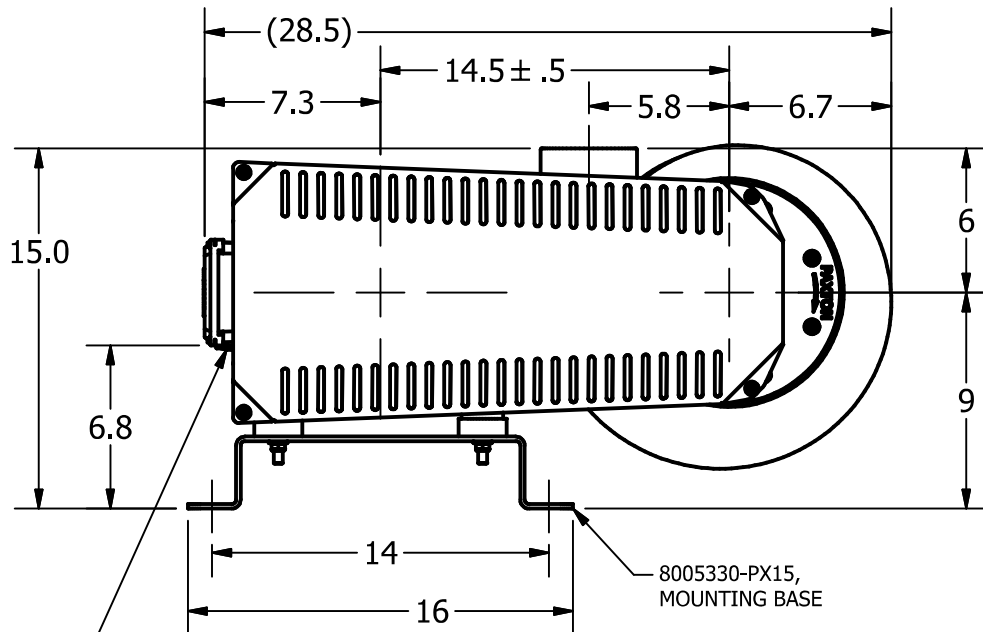

8005330-PX15,
MOUNTING BASE

1" NPT
ELECTRICAL CONNECTION

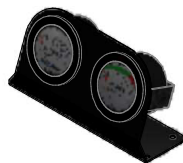

8008468, Gauge Kit
Blower Output Pressure (0-100" W/C)
Filter Pressure Drop (0-10" W/C)
With tubing and fittings

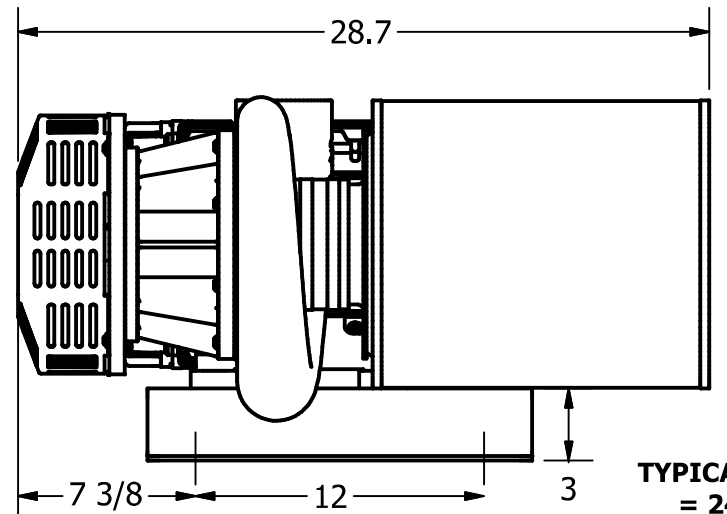

TYPICAL WT
= 245 lbs

FOR REPLACEMENT PARTS INFORMATION OR EXACT C-C DIMENSION,
PLEASE SEE THE SPECIFIC "PARTS DIAGRAM" FOR YOUR BLOWER.

THIS DOCUMENT IS THE PROPERTY
OF PAXTON PRODUCTS AND IS
FURNISHED ON THE CONDITION
THAT IT IS TO BE USED ONLY BY
PAXTON CUSTOMERS FOR
INTEGRATING PAXTON
EQUIPMENT. THIS DOCUMENT
MAY BE USED BY CUSTOMERS TO
CREATE THEIR OWN EQUIPMENT
DOCUMENTATION. OTHERWISE
THIS DOCUMENT IS NOT TO BE
USED IN ANY SHAPE OR FORM TO
CREATE DOCUMENTS, PARTS, OR
EQUIPMENT.



10125 Carver Road Phone: (800) 441-7475
Cincinnati, OH 45242 (513) 891-7474
www.paxtonproducts.com

PX-1550 Blower Drawing
15Hp, 215TC, View A-A

DATE
2/4/2016

INVENTOR DWG No.
OA-PX1500-VIEW A-A